

SEC Heat Exchangers

TITANIUM Heat Exchanger

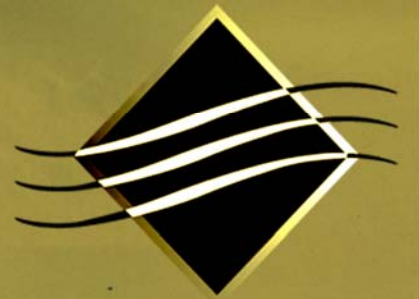

Pool Exchanger Service Manual

SECTION		PAGE
1	OPERATING PRINCIPLES	3
2	DESIGN PARAMETERS	4
3	MATERIALS OF CONSTRUCTION	4
3	DESCRIPTION OF MATERIALS	5
4	INSTALLATION / HOOK-UP	6
5	START-UP / SHUT-DOWN	7
6	MAINTENANCE	7
7	LEAK DETECTION	8
7	TRANSPORTATION / STORAGE	8
8	TROUBLESHOOTING	8
9	SALES & SERVICE	8

Pool Exchanger Service Manual

1. OPERATING PRINCIPLES

A heat exchanger is a device in which heat is transferred from one flowing fluid to another. Thermal energy is transferred through the tube walls and the total heat load is dependent on the flow parameters of the fluid.

The SEC Pool Exchanger Line of heat exchangers is designed to perform at high fluid velocities with low pressure drops. It has a helical coiled tube design that makes it distinctive from other shell and tube heat exchangers on the market today. This unique design enables efficient heat transfer performance, and allows for diversity in its applications.

Typical Applications:

- swimming pools, spas, hot tubs
- in floor heating
- driveway snowmelt
- oil coolers
- transmission and engine coolers
- boiler sample coolers
- waste water heat recovery
- marine/ saltwater applications (titanium version)

To maximize the performance of the Pool Exchanger Line of heat exchangers, the product should be installed in a counter-current flow method, as shown below in Figure 1. The hot, or heating, fluid flows through the tube side. The cold, or heated, fluid flows through the shell side.

Example: for swimming pool applications, the pool water is to flow through the shell side, and the boiler water is to flow through the tube side.

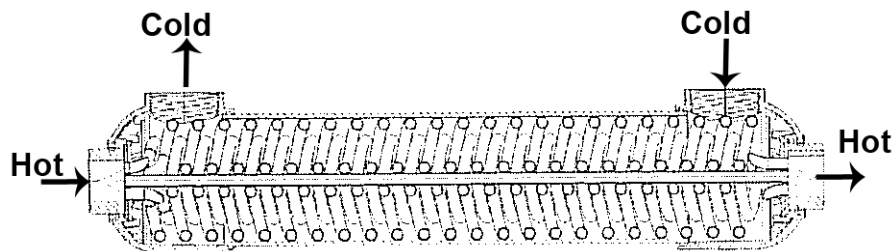

Fig.1 Typical Flow Diagram

These products are equipped with mounting brackets to assist in their installation and ease of use.

Under no circumstances should there be pulsating of fluids in the system, as this causes vibrations that could damage the structural integrity of the heat exchanger. The system should be designed to prevent the unit from encountering pressure shocks and rapid temperature changes.

Pool Exchanger Service Manual

2. DESIGN PARAMETERS:

Shell Side Pressure: 35 PSI
Shell Side Temperature: 120 F
Tube Side Pressure: 145 PSI
Tube Side Temperature: 200 F

**** WARNINGS****

DO NOT exceed these design parameters! Failure to adhere to these parameters may result in equipment damage and/or personal injuries.

HOT SURFACE

Contact surfaces may be extremely hot during operation. **Do not touch!**
Use extreme caution while in close proximity. Failure to do so may result in personal injuries.

3. MATERIALS OF CONSTRUCTION

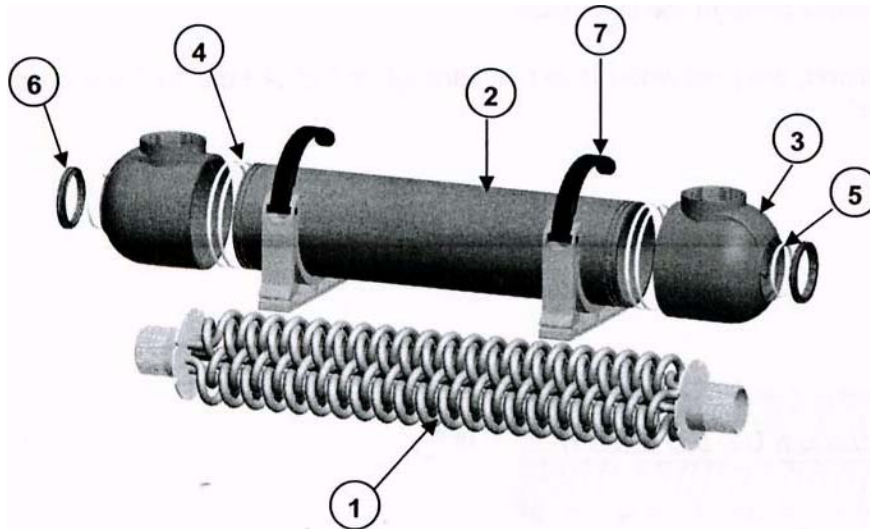

Items	Component	Qty	Material
1	Helical Tube Bundle	1	Titanium or 316L Stainless Steel
2	Shell	1	Unplasticized Polyvinyl Chloride (PVCU)
3	Head	2	Polyphthalamide, 40% Glass Fiber
4	Shell Gasket	4	Nitrile / EPDM
5	Nozzle Gasket	2	Nitrile / EPDM
6	Tightening Nut	2	Plastic
7	Support Bracket (pair)	1	Plastic

The helical tube bundles are available in both Titanium and Stainless Steel materials. Stainless steel tube bundles should not be used in applications that involve high chloride levels or sea/saltwater. The Titanium tube bundles are recommended in these cases.

Pool Exchanger Service Manual

4. DESCRIPTION OF MATERIALS:

Heat Transfer Surface:

1. Commercial Pure Titanium (CP Ti) exhibits exceptional resistance to a vast range of chemical environments and conditions, due to a thin, invisible, but extremely protective, surface oxide film (primarily TiO₂). Titanium (Ti) is especially known for its elevated resistance to localized attack and stress corrosion in aqueous chlorides (e.g., brines, seawater) and other halides and wet halogens (e.g., wet Cl₂ or Cl₂-sat, brines), and to hot, highly-oxidizing, acidic solutions (e.g., FeCl₃ and nitric acid solutions). Ti is also recognized for its superior resistance to erosion, erosion-corrosion, cavitation, and impingement in flowing, turbulent fluids.

2. The low ("L" .03 max) carbon versions of stainless steel (SS) 316 in wrought and cast compositions is used for welded applications. The thin chromium oxide film to which SS owes its corrosion resistance forms almost instantly in air, water, or other media containing oxygen. Dissolved oxygen is the principal constituent of water that affects the corrosion behaviour of SS and the effect is highly beneficial. The agitation, turbulence, and high velocity of water that were troublesome to carbon steel, cast and ductile iron, are highly beneficial to the durability and performance of SS.

Head:

Polyphthalamide, 40% filled with glass fiber is a thermoplastic construction material based on a semi-crystalline, partially aromatic polyamide (PA6T/X). In comparison to other well-known polyamides it is characterised by its very high performance profile at high temperatures, owing it to a specially heat stabilised injection molding process. It is particularly suitable and approved for parts in house-hold appliances in contact with food and drinking water. The main distinguishing feature of polyphthalamide, when compared to other polyamides, is its good performance values at high temperatures providing parts which are stiffer, stronger and have better heat distortion stability and chemical resistance.

Shell:

Unplasticized Polyvinyl Chloride (PVCU) is a widely used construction resin, commonly used as a material for producing pipes. Good mechanical properties in terms of creep, viscoelasticity, and fatigue are very important and are maintained over prolonged periods of time (products are evaluated for creep, and data are extrapolated up to 100 years when necessary with high safety coefficient) The visco-elasticity of the material permits an exceptional behavior concerning the interactions between the shell of a heat exchanger and the coil bundle inside. PVC is inert to a lot of materials, including disinfectants used in the treatment of potable water.

Gaskets:

1. Ethylene Propylene, and Ethylene Propylene Diene rubber (EPM, EPDM), has been accepted in the sealing industry because of its excellent resistance to heat, water and steam, alkali, mild acidic and oxygenated solvents, ozone, and sunlight. These compounds also withstand the affect of brake fluids and Skydrol™ and other phosphate ester-based hydraulic fluids. EPDM compounds are not recommended for gasoline, petroleum oil and grease, and hydrocarbon environments. Special EPDM compounds have good resistance to steam.

2. Acrylonitrile butadiene, Nitrile or Buna N (NBR). Nitrile, chemically, is a copolymer of butadiene and acrylonitrile. Acrylonitrile content varies in commercial products from 18% to 50%. As the nitrile content increases, resistance to petroleum base oils and hydrocarbon fuels increases, but low temperature flexibility decreases. Nitrile compounds are superior to most elastomers with regard to compression set, tear, and abrasion resistance. NBR is the standard material for hydraulics and pneumatics. NBR resists oil-based hydraulic fluids, fats, animal and vegetable oils, flame retardant liquids (HFA, HFB.HFC), grease, water, and air.

****IMPORTANT NOTE****

It is the purchaser's responsibility to ensure that all fluids in contact with the product are compatible with the construction material of the product. This includes operational fluids and cleaning fluids. Corrosive environments are often a combination of chemical levels, flow rates, and temperatures. Failure to ensure this will result in damages to the product.

Pool Exchanger Service Manual

5. INSTALLATION / HOOK-UP:

The Pool Exchanger can be mounted in either the vertical or horizontal position. All pipes connected to the heat exchanger are recommended to be equipped with shut-off valves so that the heat exchanger can be removed for maintenance purposes, or be isolated (using a bypass line) if required.

Couplings that are threaded into the head of the heat exchanger (e.g. pool water lines) should be made of plastic or any compatible material. Pipes connected to the unit should be mounted so that any stresses or strains in the system (e.g. caused by thermal expansions) would not translate to the heat exchanger.

Figure 2 is an example of a typical installation. The heat exchanger should have safety relief valves installed on both sides of the product.

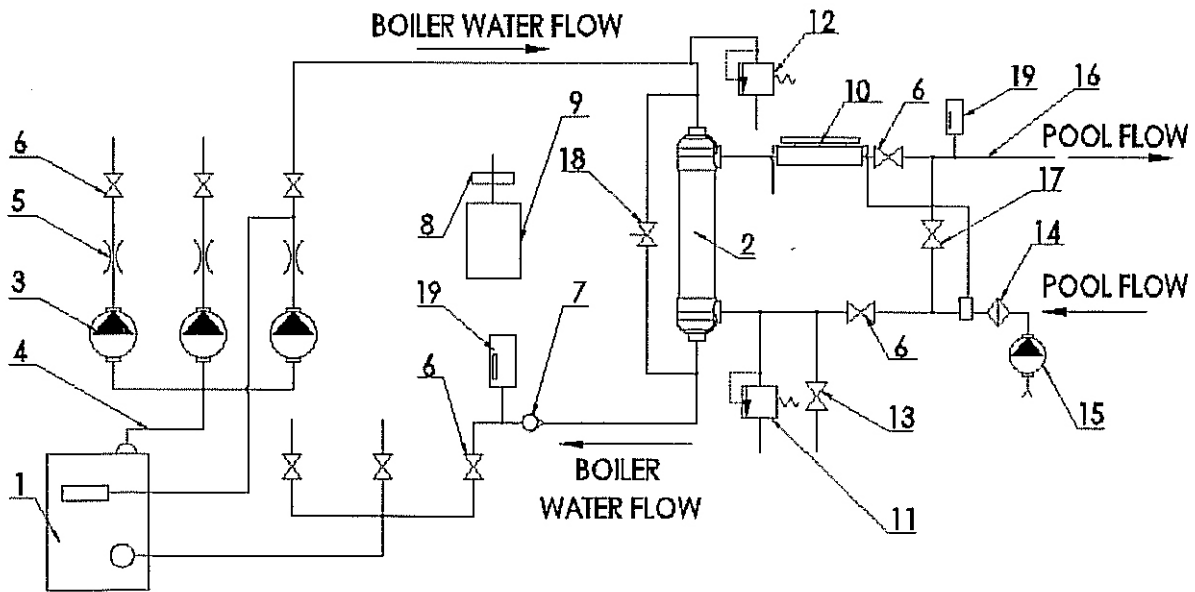

Fig. 2 Typical Pool Installation

1. Boiler	11. Safety Relief Valve
2. Heat Exchanger	12. Safety Relief Valve
3. Circulation Pump	13. Drain Valve
4. Boiler Water Circuit	14. Filtration
5. Flow Control Valve	15. Pump
6. Gate Valve	16. Water Supply
7. Check Valve	17. Bypass Valve
8. ON / OFF Switch	18. Bypass Control Valve
9. Relat	19. Thermometer
10. Flow Switch	

Pool Exchanger Service Manual

6. START-UP / SHUT-DOWN:

Inspect the equipment prior to startup. Ensure that the system is clean of debris before starting operation to prevent clogging of the tubes and the shell side passages. Open vent connections before starting up. In all startup and shutdown operations, fluid flows should be gradual and regulated to avoid thermal shocking the unit, and every effort should be made to prevent subjecting the heat exchanger to overpressure or hydraulic hammers, as these conditions may impose stresses on the unit that could result in structural damages.

Start-Up:

- Valves should be opened gradually to achieve a steady increase in flow and pressure into the unit.
- The cold (heated) fluid should first enter into the system.
- The hot (heating) fluid, water or steam, should be gradually brought into the system.
- Check all connections for leaks.

Shut-Down:

- Shut down hot fluid side first, then the cold fluid side.

Prevent any of the fluids from dropping below their freezing point. Drain all fluids when shutting down to prevent possible freezing and corrosion.

7. MAINTENANCE:

It is important to have a regular maintenance program to ensure the longevity, and the effectiveness, of the Pool Exchanger.

Heat exchangers are subject to fouling (scale buildup, sludge deposits, hard water deposits, tarnishes, etc.) periodically, depending on operating conditions. Fouling in the unit can result in increased pressure drops, low temperature differential in the heated medium, or a higher exit temperature on the heating medium side.

To clean or inspect the tubes, it may be necessary to remove the tube bundle from the shell. When removing the tube bundle, ensure that there is no damage due to improper handling.

Cleaning of the heat exchanger can be done without removing the tube bundles or the unit from the system, although extra connections and bypasses will be required.

Cleaning solutions are available at most businesses who carrying chemical cleaning agents for heat exchangers or tubing and piping applications. As a guideline for purchasing the cleaning solutions, check for the following product data:

- compatibility with the material of construction (stainless steel, titanium, pvc, etc.)
- acceptable for use in food processing industries (if applicable)
- effectively removes scale, slag, tarnishes, and hard water deposits
- easily rinsed out of the system
- no objectionable or corrosive fumes

****WARNING****

The following fluids are prohibited for use as a flushing agent for stainless steel tube bundles

- Hydrochloric acid up to 0.1% concentration
- Solutions that contain MCI
- Chlorides (MgCl₂, NaCl between 0.01-1%, CuCl up to 1%, CaCl₂ from 5% to saturation)
- Any fluid that will deposit alkaline residue or phosphorous

Pool Exchanger Service Manual

8. LEAK DETECTION:

External leaks are easily visible, and depending on the location of the leaks, replacement gaskets may be required.

To assess if a unit has an internal leak:

- disconnect the tube side connections, and drain it of all fluid and moisture
- pressurize the shell side (with water, in most cases), and observe the tube side for signs of the test fluid

The tube bundle may be removed from the unit for closer inspection.

9. TRANSPORTATION / STORAGE:

During transportation of the heat exchanger(s), ensure that they are not exposed to mechanical damages. Upon receipt of the heat exchanger, inspect the unit for shipping damages. Notify the carrier or SEC sales office immediately in the event that such damages does occur.

Heat exchangers should be stored in a clean, dry, low humidity area away from corrosive environments or weather elements (e.g. rain, snow, blowing dust). If the unit is not to be placed in immediate service, take precautions to prevent rusting or contamination. Heat exchangers that are out of service for extended periods of time should be protected against corrosion.

10. TROUBLE SHOOTING:

In many cases, issues with the system may not involve, or be related to, the heat exchanger itself. Below are a few common, system-related issues.

Problem: No performance (heat)

Possible causes:

- The heat exchanger is not completely filled with water in both circuits.
- The heat exchanger is not deaerated properly.
- Insufficient flow at heating circuit.
- Strainer clogged on Boiler or Pool side (circuit).
- Wrong setting of thermostat or of automatic controls, if any.
- Defective sensor on self-acting thermostat

11. SALES & SERVICE CONTACT:

SEC Heat Exchangers serves its customers and the public through a network of distributors. For application assistance, performance specifications, pricing, or the name of the nearest Authorized Distributor, contact us at:



Systems Equipment Corporation ("SEC Heat Exchangers")
2546 Iona Road, Belfast, PE, Canada C0A 1A0
TEL: 902.659.2424 FAX: 902.659.2800 TOLL FREE: 1.800.335.6650
Web www.heatexchangers.ca or send your inquiry to info@secheatexchangers.com